

# JET BROACH

## & ACCESSORIES OF ANNULAR CUTTER



1. Suitable for cutting holes on various materials with high speed.
2. Selected special-purpose carbide tips for reduced damage of tips and better endurance.
3. Multi-cut geometry for increased chip removal and less resistance.
4. Various shank versions fit all magnetic drills and press.
5. Diameter from  $\text{Ø}12\sim\text{Ø}150\text{mm}$ , Cutting depth: 35mm, 50mm, 75mm and 100mm.
6. Special dimensions  $\text{Ø}150\text{mm}\sim\text{Ø}200\text{mm}$  with 200mm D.O.C are available.

# PRODUCTION PROCESS



ผลิตด้วยเครื่อง CNC Vertical Machining Center  
สำเร็จในเครื่องเดียว จึงมั่นใจในความเที่ยงตรง  
ศูนย์กลางแม่นยำ เจาะไม่แกว่ง  
เมื่อประกอบเข้าชุดพร้อมใช้งาน  
จะมีค่า Tolerance เพียง 0.1 mm.

ด้วยกระบวนการผลิตอย่างมืออาชีพ การันตีคุณภาพ  
เทียบเท่ากับหลายแบรนด์ดังชั้นนำระดับโลก  
เช่น Fein, Hougén, Jancy, Rotabroach



**ตัวพินที่เป็นคาร์ไบด์  
ผลิตโดยบริษัท SANDVIK  
จากประเทศสวีเดน  
เป็นคาร์ไบด์ที่ดีที่สุดในโลก**



## Main Facilities

- |  |   |
|--|---|
| <b>CNC Lathe</b>                           | Process of turning the outer diameter of the cutter body, boring the cutter bore and pilot bore |
| <b>CNC Universal lifts Milling machine</b> | Process of milling cutter flutes  |
| <b>CNC Vertical Machining Center</b>       | Multi-faceted process of cutter body  |
| <b>High precision Centerless grinder</b>   | Process of grinding the the outer diameter of cutter body and shank                             |
| <b>Vacuum CNC soldering machine</b>        | Process of heat treatment<br>Process of soldering carbide teeth on cutter body                  |
| <b>CNC Grinder (ANKA Brand)</b>            | Process of grinding the cutter teeth, lands, flutes   |
| <b>Ultrasonic Wave Cleansing machine</b>   | Process of cleansing cutter   |
| <b>Laser-marking machine</b>               | Process of etching on cutter shank  |

## Test instruments

- |   |  |
|---|--|
| <b>OBLF Value Reading Spectrometer GS1000</b> | Testing of metallic materials of various chemical elements   |
| <b>Nikon Metallurgical Microscope</b>         | Testing microstructure of metallic materials   |
| <b>ZOLLER Measuring Instrument</b>            | Detecting geometries and angles of cutting tools   |
| <b>Microscope of Cutting Tools</b>            | Detecting geometries and angles of cutting tools   |
| <b>Torsion Testing Machine</b>                | Testing mechanical properties of metallic materials  |
| <b>Hardness Tester</b>                        | Rockwell hardness testing of metallic materials  |
| <b>Universal hydraulic testing instrument</b> | Detecting anti-stress & anti-clip force on part of cutter. e.g.: Carbide teeth soldered on the cutter body |





● Used on magnetic drill



● Hole saws used on the pistol drill



● Used on the drill machine



● Used on the upright drill

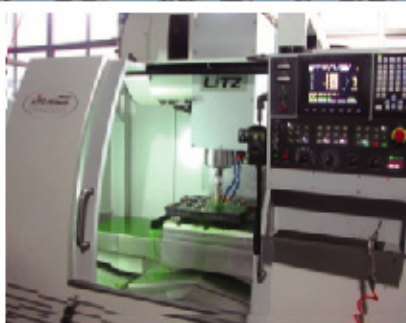

● Used on the CNC machine



● Used on the radial drill machine

# CUTTING APPLICATION

## ประสิทธิภาพในการเจาะขึ้นอยู่กับปัจจัยดังต่อไปนี้

- เลือกใช้ดอก Jet Broach ให้เหมาะสมกับประเภทชิ้นงานที่จะตัด Materials to be cut.
  - ต้องเลือกใช้เครื่องเจาะที่มีคุณภาพ มีแกนหมุนที่แข็งแรง เนื่องจากการเจาะจะเกิดแรงบิดที่สูงมาก หากเครื่องมือที่ใช้เจาะไม่มั่นคงแข็งแรง ก็จะทำให้เกิดการแกว่ง ดอก Jet Broach ก็อาจจะแตกหัก หรือร้าวได้ ควรเลือกใช้เครื่องเจาะที่มีชื่อเสียง สามารถเชื่อถือได้ในคุณภาพ เช่น Nitto, Fein, Hougén, Jancy, Rotabroach และ Macxicut
- The rigidity of the spindle of the drilling machines.



- ต้องเป็นช่างผู้ชำนาญ ที่มีประสบการณ์ในการเจาะ แล้วต้องใช้ความแข็งแรงในการจับยึดอุปกรณ์ให้มั่นคงขณะทำการเจาะ
- The rigidity of the holder of the drilling machines.
- ความสัมพันธ์ของความเร็วยรอบและ Feed ของเครื่องเจาะ RPM & feed of the drilling machines.
  - การทำงานของระบบจ่ายน้ำหล่อเย็นที่มีประสิทธิภาพ Coolant supply.
  - การอ่านทำความเข้าใจคู่มือ เพื่อการใช้งานที่ถูกต้อง Operators' manual.

ตารางแสดงความสามารถที่ดอก JET BOACH สามารถเจาะวัสดุต่างๆ ได้

	เหล็ก (Steel) <500 N			อลูมิเนียม (Aluminum) <10% Si	
	เหล็ก (Steel) <750 N			อลูมิเนียม (Aluminum) >10% Si	
	เหล็ก (Steel) <900 N			ทองแดง,ทองเหลือง,ดีบุก (Copper, brass, tin)	
	เหล็ก (Steel) <1100 N			พลาสติก, GRP/CRP (Plastics, GRP/CRP)	
	เหล็ก (Steel) <1400 N			เหล็กหล่อ (Grey cast iron)	
	สแตนเลส (Stainless) <900 N			แกรไฟต์ (Graphit)	
	สแตนเลส (Stainless) >900 N			Hardox, Hastelloy, Inconell, Nimonic, exotic material	
	Rails (รางไฟฟ้า)				

 เจาะได้ดีเยี่ยม (Excellent)

 เจาะได้ดี (Good)

 สามารถเจาะได้ (Possible)

## ● Description of types of annular cutter ranges

### DAHX – 25

Type	Product		Performance		Material		Shank		Code of D.O.C.	
	Code	Description	Code	Description	Code	Description	Code	Description	Code	Depth of cut
DAHX-	D	Annular cutter	A	High-performance	H	HSS	X	3/4" weldon shank	10	≤10mm
DAHK-	D	Annular cutter	A	High-performance	H	HSS	K	3/4" weldon shank with holes	25	25mm
DNHX-	D	Annular cutter	N	Standard	H	HSS	X	3/4" weldon shank	35	35mm
DNHK-	D	Annular cutter	N	Standard	H	HSS	K	3/4" weldon shank with holes	50	50mm
DBHX-	D	Annular cutter	B	Benefit	H	HSS	X	3/4" weldon shank	75	75mm
DBHK-	D	Annular cutter	B	Benefit	H	HSS	K	3/4" weldon shank with holes	100	100mm
DAHC-	D	Annular cutter	A	High-performance	H	HSS	C	3/4" universal shank(3 holes)	A	≤1/2"
DNHF-	D	Annular cutter	N	Standard	H	HSS	F	18 fein quick-in shank	B	1"
DNHL-	D	Annular cutter	N	Standard	H	HSS	L	M18*6/P1.5 thread shank	C	1-3/8"
DNTX-	D	Annular cutter	N	Standard	T	TCT	X	3/4" weldon shank	D	2"
DNTK-	D	Annular cutter	N	Standard	T	TCT	K	3/4" weldon shank with holes	E	3"
DNTC-	D	Annular cutter	N	Standard	T	TCT	C	3/4" universal shank(3 holes)	F	4"
DNTF-	D	Annular cutter	N	Standard	T	TCT	F	18 fein quick-in shank		
DNTL-	D	Annular cutter	N	Standard	T	TCT	L	M18*6/P1.5 thread shank		
DNTP-	D	Annular cutter	N	Standard	T	TCT	P	1-1/4" weldon shank		
DNTJ-	D	Annular cutter	N	Standard	T	TCT	F	1-1/4" *2-3/8" weldon shank		
DNTG-	D	Annular cutter	N	Standard	T	TCT	G	25mm quick change shank		
DP	DP	Annular cutter accessory-pilot								
DJ	DJ	Annular cutter accessory-arbor								
DZ	DZ	Annular cutter accessory-adapter								

● Code of D.O.C. showed as digital are metric diameter  
 ● Code of D.O.C. showed as letter are imperial diameter

## ● Types of rail cutters

### DRAX – 25

Model	TYPE		PROPERTY & MATERIAL		shank		code of D.O.C.	
	Code	Description	Code	Description	Code	Description	Code	cutting depth
DRAX-	DR	rail core drill	A	high-performance HSS	X	19 weldon shank	25	25mm
DRHX-	DR	rail core drill	H	super tough HSS	X	19 weldon shank	50	50mm
DRSX-	DR	rail core drill	S		X	19 weldon shank		
DRTX-	DR	rail core drill	T	T.C.T	X	19 weldon shank		
SRHX-	SR	solide rail cutter	H	HSS	X	19 weldon shank		
SKSY-	SK		S		Y	19 weldon shank		



T.C.T annular cutter with Universal shank  
TC สำหรับ Diameter ไม่เกิน 60 mm

ตัวพินที่เป็นคาร์ไบด์  
ผลิตโดยบริษัท SANDVIK  
จากประเทศสวีเดน  
เป็นคาร์ไบด์ที่ดีที่สุดในโลก



# JET BROACH

ที่คุณภาพดีที่สุดในโลก  
The best quality in the world



## DNTC-35

3/4" Universal shank (3 hole)  
Tolerance 0.0001 mm.

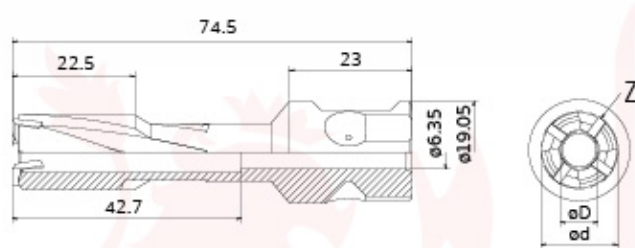

d (mm)	D (mm)	Z	Price
▶ 12	6	4	1,914.-
▶ 13	6	4	1,914.-
▶ 14	7	4	1,914.-
▶ 15	8	4	1,914.-

▶ มีสินค้า

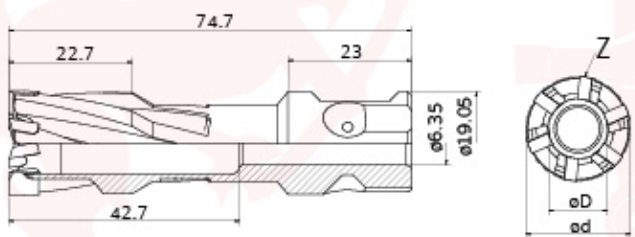

d(mm)	D(mm)	Z	Price
▶ 16	9	6	1,914.-
▶ 17	10	6	1,914.-

▶ มีสินค้า

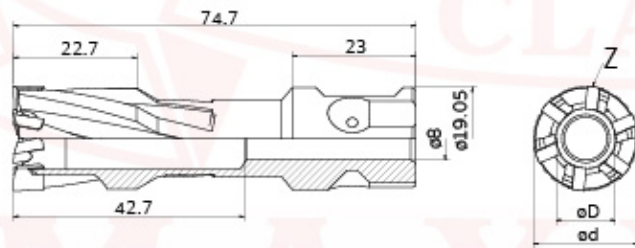

d(mm)	D(mm)	Z	Price
▶ 18	10.5	6	1,914.-
▶ 19	11	6	1,914.-
▶ 20	12	6	1,914.-
▶ 21	13	6	1,914.-
▶ 22	14	6	1,914.-
▶ 23	15	6	1,914.-

▶ มีสินค้า

D : เส้นผ่านศูนย์กลางวงใน d : เส้นผ่านศูนย์กลางวงนอก  
Z : จำนวนร่องพิน

- Universal shank for various magnetic drills.
- Selected special-purpose carbide tips with multi-cut geometry for ply-cutting and lower friction. Reduced damage of tips and improved performance of chips removal
- Applicable to hole cutting and process of annular groove on various magnetic drill and press

Suitable pins			
Type	Size	Matching Cutter	Price
▶ DPB	6.34x90	12mm~17mm	240.-
▶ DPB	8x90	≥18mm	240.-



T.C.T annular cutter with Universal shank  
TC สำหรับ Diameter ไม่เกิน 60 mm

ตัวพินที่เป็นคาร์ไบด์  
ผลิตโดยบริษัท SANDVIK  
จากประเทศสวีเดน  
เป็นคาร์ไบด์ที่ดีที่สุดในโลก

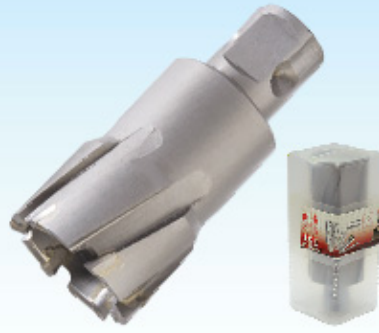

## DNTC-35

3/4" Universal shank (3 hole)  
Tolerance 0.0001 mm.

**JET BROACH**  
ที่คุณภาพดีที่สุดในโลก  
The best quality in the world

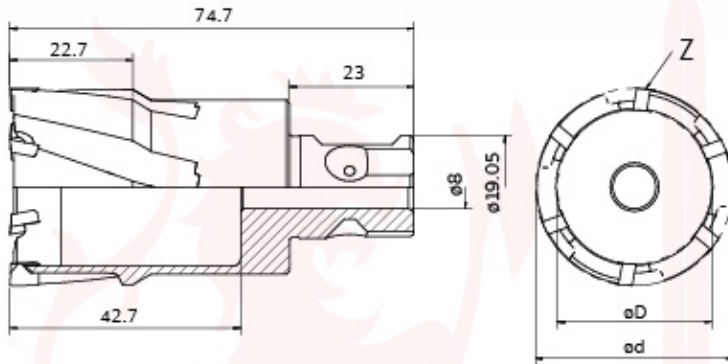

d(mm)	D(mm)	Z	Price
▶ 24	16	6	1,914.-
▶ 25	17	6	1,914.-
▶ 26	18	6	2,108.-
▶ 27	19	6	2,108.-
▶ 28	20	6	2,108.-
▶ 29	21	6	2,108.-
▶ 30	22	6	2,108.-
▶ 31	23	6	2,464.-
▶ 32	24	6	2,464.-
▶ 33	25	6	2,464.-
▶ 34	26	6	2,464.-
▶ 35	27	6	2,464.-
▶ 36	28	6	2,806.-
▶ 37	29	6	2,806.-
▶ 38	30	6	2,806.-
▶ 39	31	6	2,806.-
▶ 40	32	6	2,806.-
▶ 41	33	6	3,475.-
▶ 42	34	6	3,475.-
▶ 43	35	6	3,475.-
▶ 44	36	6	3,475.-
▶ 45	37	6	3,968.-

▶ มีสินค้า

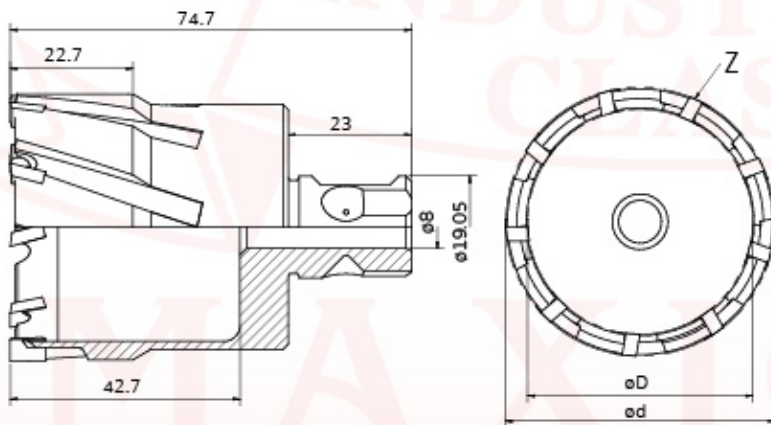

d(mm)	D(mm)	Z	Price
▶ 46	38	9	3,968.-
▶ 47	39	9	3,968.-
▶ 48	40	9	3,968.-
▶ 49	41	9	3,968.-
▶ 50	42	9	3,968.-
▶ 51	43	9	4,492.-
▶ 52	44	9	4,492.-
▶ 53	45	9	4,492.-
▶ 54	46	9	4,492.-
▶ 55	47	9	4,492.-
▶ 56	48	9	4,938.-
▶ 57	49	9	4,938.-
▶ 58	50	9	4,938.-
▶ 59	51	9	4,938.-
▶ 60	52	9	4,938.-
▶ 61	53	9	5,675.-
▶ 62	54	9	5,675.-
▶ 63	55	9	5,675.-
▶ 64	56	9	5,675.-
▶ 65	57	9	5,675.-

▶ มีสินค้า

D : เส้นผ่านศูนย์กลางวงใน d : เส้นผ่านศูนย์กลางวงนอก  
Z : จำนวนร่องพิน

- Universal shank for various magnetic drills.
- Selected special-purpose carbide tips with multi-cut geometry for ply-cutting and lower friction. Reduced damage of tips and improved performance of chips removal
- Applicable to hole cutting and process of annular groove on various magnetic drill and press

### Suitable pins

Type	Size	Matching Cutter	Price
▶ DPB	6.34x90	12mm~17mm	240.-
▶ DPB	8x90	≥18mm	240.-



T.C.T annular cutter with Universal shank  
 TC สำหรับ Diameter ไม่เกิน 60 mm

ตัวพินที่เป็นคาร์ไบด์  
 ผลิตโดยบริษัท SANDVIK  
 จากประเทศสวีเดน  
 เป็นคาร์ไบด์ที่ดีที่สุดในโลก



# JET BROACH

ที่คุณภาพดีที่สุดในโลก  
 The best quality in the world



## DNTC-50

3/4" Universal shank (3 hole)  
 Tolerance 0.0001 mm.

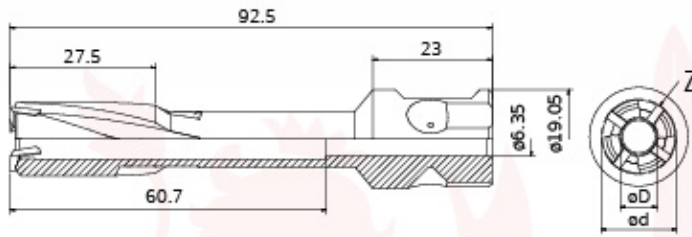

d(mm)	D(mm)	Z	Price
▶ 12	6	4	2,166.-
▶ 13	6	4	2,166.-
▶ 14	7	4	2,166.-
▶ 15	8	4	2,166.-

▶ มีสินค้า

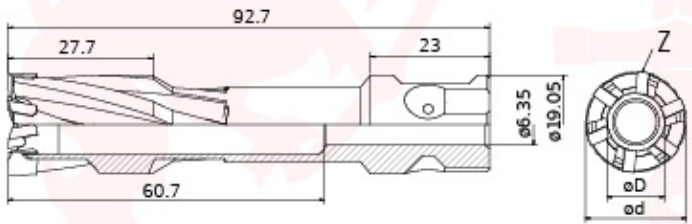

d(mm)	D(mm)	Z	Price
▶ 16	9	6	2,166.-
▶ 17	10	6	2,166.-

▶ มีสินค้า

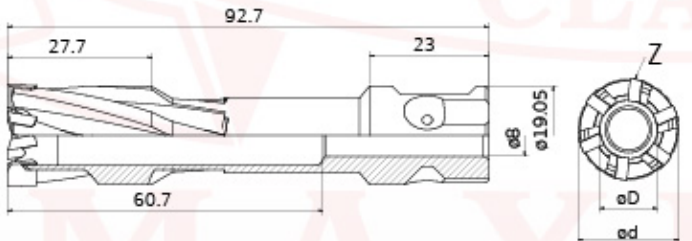

d(mm)	D(mm)	Z	Price
▶ 18	10.5	6	2,166.-
▶ 19	11	6	2,166.-
▶ 20	12	6	2,166.-
▶ 21	13	6	2,166.-
▶ 22	14	6	2,166.-
▶ 23	15	6	2,166.-

▶ มีสินค้า

D : เส้นผ่านศูนย์กลางวงใน d : เส้นผ่านศูนย์กลางวงนอก  
 Z : จำนวนร่องพิน

- Universal shank for various magnetic drills.
- Selected special-purpose carbide tips with multi-cut geometry for ply-cutting and lower friction. Reduced damage of tips and improved performance of chips removal
- Applicable to hole cutting and process of annular groove on various magnetic drill and press

### Suitable pins

Type	Size	Matching Cutter	Price
▶ DPB	6.34x106	12mm~17mm	280.-
▶ DPB	8x105	≥18mm	280.-





T.C.T annular cutter with Universal shank  
 TC สำหรับ Diameter ไม่เกิน 60 mm

ตัวพินที่เป็นคาร์ไบด์  
 ผลิตโดยบริษัท SANDVIK  
 จากประเทศสวีเดน  
 เป็นคาร์ไบด์ที่ดีที่สุดในโลก



# JET BROACH

ที่คุณภาพดีที่สุดในโลก  
 The best quality in the world



## DNTC-50

3/4" Universal shank (3 hole)  
 Tolerance 0.0001 mm.

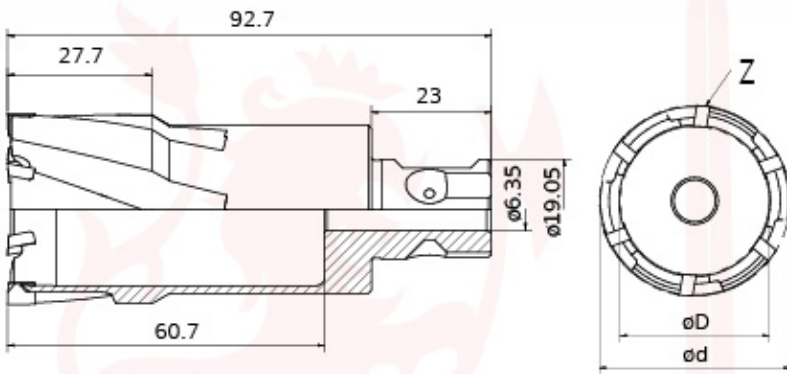

d(mm)	D(mm)	Z	Price
▶ 24	16	6	2,166.-
▶ 25	17	6	2,166.-
▶ 26	18	6	2,356.-
▶ 27	19	6	2,356.-
▶ 28	20	6	2,356.-
▶ 29	21	6	2,356.-
▶ 30	22	6	2,356.-
▶ 31	23	6	2,833.-
▶ 32	24	6	2,833.-
▶ 33	25	6	2,833.-
▶ 34	26	6	2,833.-
▶ 35	27	6	2,833.-
▶ 36	28	6	3,244.-
▶ 37	29	6	3,244.-
▶ 38	30	6	3,244.-
▶ 39	31	6	3,244.-
▶ 40	32	6	3,244.-
▶ 41	33	6	4,230.-
▶ 42	34	6	4,230.-
▶ 43	35	6	4,230.-
▶ 44	36	6	4,230.-
▶ 45	37	6	4,230.-

▶ มีสินค้า

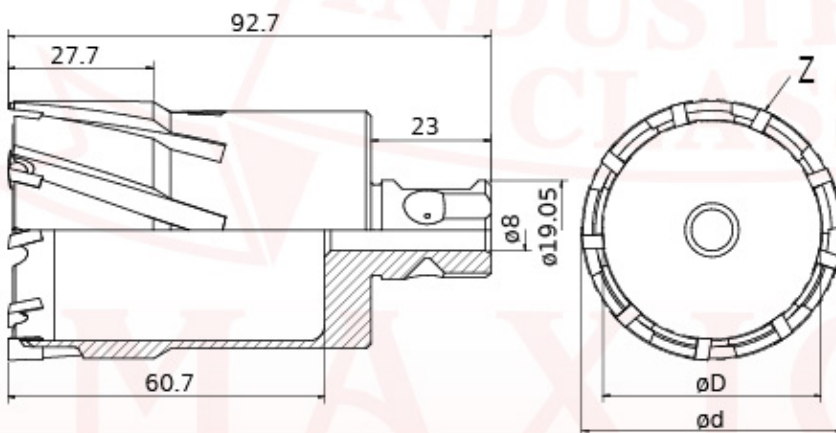

d(mm)	D(mm)	Z	Price
▶ 46	38	9	4,880.-
▶ 47	39	9	4,880.-
▶ 48	40	9	4,880.-
▶ 49	41	9	4,880.-
▶ 50	42	9	4,880.-
▶ 51	43	9	5,518.-
▶ 52	44	9	5,518.-
▶ 53	45	9	5,518.-
▶ 54	46	9	5,518.-
▶ 55	47	9	5,518.-
▶ 56	48	9	6,152.-
▶ 57	49	9	6,152.-
▶ 58	50	9	6,152.-
▶ 59	51	9	6,152.-
▶ 60	52	9	6,152.-
▶ 61	53	9	7,010.-
▶ 62	54	9	7,010.-
▶ 63	55	9	7,010.-
▶ 64	56	9	7,010.-
▶ 65	57	9	7,010.-

D : เส้นผ่านศูนย์กลางวงใน d : เส้นผ่านศูนย์กลางวงนอก  
 Z : จำนวนร่องพิน

- Universal shank for various magnetic drills.
- Selected special-purpose carbide tips with multi-cut geometry for ply-cutting and lower friction. Reduced damage of tips and improved performance of chips removal
- Applicable to hole cutting and process of annular groove on various magnetic drill and press

### Suitable pins

Type	Size	Matching Cutter	Price
▶ DPB	6.34x106	12mm-17mm	280.-
▶ DPB	8x105	≥18mm	280.-



T.C.T annular cutter with Universal shank  
 TC สำหรับ Diameter ไม่เกิน 60 mm

ตัวพิมพ์ที่เป็นคาร์ไบด์  
 ผลิตโดยบริษัท SANDVIK  
 จากประเทศสวีเดน  
 เป็นคาร์ไบด์ที่ดีที่สุดในโลก



# JET BROACH

ที่คุณภาพดีที่สุดในโลก  
 The best quality in the world



**DNTC-75**

Tolerance 0.0001 mm.

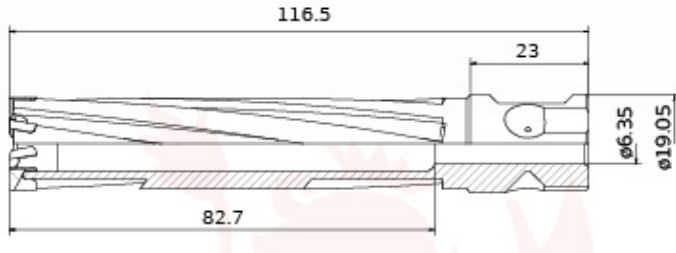

d(mm)	D(mm)	Z	Price
14	6.5	4	X,XXX.-
15	7.5	4	X,XXX.-
16	8	4	X,XXX.-
17	9	4	X,XXX.-

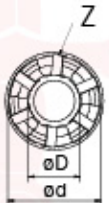
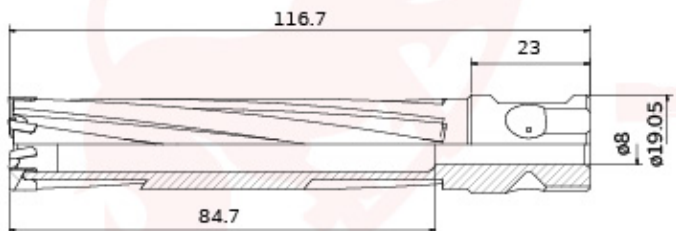

d(mm)	D(mm)	Z	Price
▶ 18	10	6	3,310.-
▶ 19	11	6	3,310.-

▶ มีสินค้า

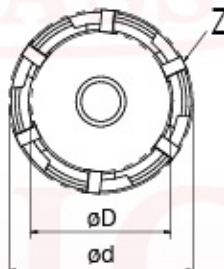
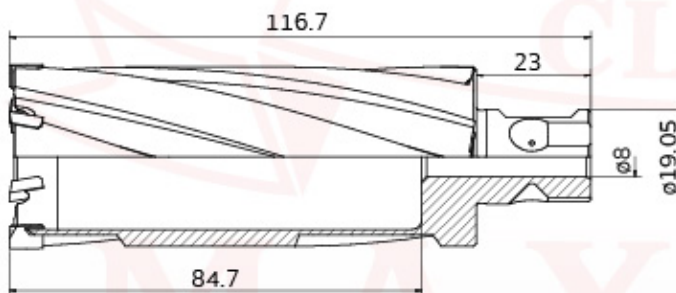

d(mm)	D(mm)	Z	Price
▶ 20	12	6	3,310.-
▶ 21	13	6	3,310.-
▶ 22	14	6	3,310.-
▶ 23	15	6	3,310.-
▶ 24	16	6	3,310.-
▶ 25	17	6	3,310.-
▶ 26	18	6	3,598.-
▶ 27	19	6	3,598.-
▶ 28	20	6	3,598.-
▶ 29	21	6	3,598.-
▶ 30	22	6	3,598.-

▶ มีสินค้า

D : เส้นผ่านศูนย์กลางวงใน d : เส้นผ่านศูนย์กลางวงนอก  
 Z : จำนวนร่องฟัน

- Universal shank for various magnetic drills.
- Selected special-purpose carbide tips with multi-cut geometry for ply-cutting and lower friction. Reduced damage of tips and improved performance of chips removal
- Applicable to hole cutting and process of annular groove on various magnetic drill and press

Suitable pins

Type	Size	Matching Cutter	Price
DPB	8x130	18mm-60mm	500.-
DPT	8x130	18mm-60mm	



T.C.T annular cutter with Universal shank  
 TC สำหรับ Diameter ไม่เกิน 60 mm

ตัวพิมพ์ที่เป็นคาร์ไบด์  
 ผลิตโดยบริษัท SANDVIK  
 จากประเทศสวีเดน  
 เป็นคาร์ไบด์ที่ดีที่สุดในโลก



# JET BROACH

ที่คุณภาพดีที่สุดในโลก  
 The best quality in the world



**DNTC-75**

Tolerance 0.0001 mm.

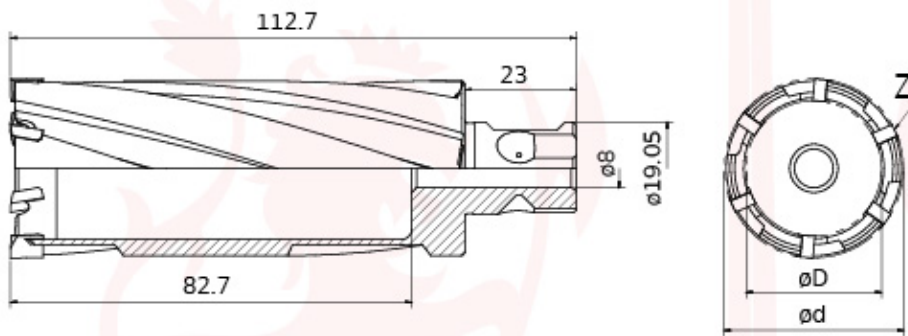

d(mm)	D(mm)	Z	Price
▶ 31	23	6	4,345.-
▶ 32	24	6	4,345.-
▶ 33	25	6	4,345.-
▶ 34	26	6	4,345.-
▶ 35	27	6	4,345.-
▶ 36	28	6	5,012.-
▶ 37	29	6	5,012.-
▶ 38	30	6	5,012.-
▶ 39	31	6	5,012.-
▶ 40	32	6	5,012.-
▶ 41	33	6	5,923.-
▶ 42	34	6	5,923.-
▶ 43	35	6	5,923.-
▶ 44	36	6	5,923.-
▶ 45	37	6	5,923.-

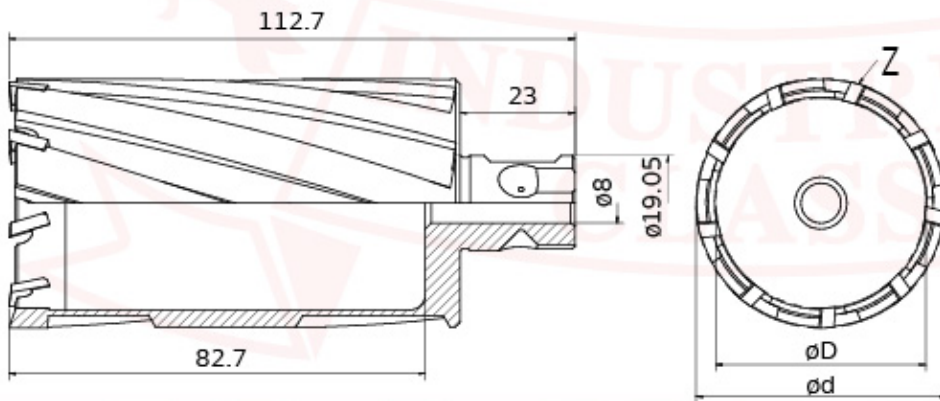

d(mm)	D(mm)	Z	Price
▶ 46	38	9	7,110.-
▶ 47	39	9	7,110.-
▶ 48	40	9	7,110.-
▶ 49	41	9	7,110.-
▶ 50	42	9	7,110.-
▶ 51	43	9	7,945.-
▶ 52	44	9	7,945.-
▶ 53	45	9	7,945.-
▶ 54	46	9	7,945.-
▶ 55	47	9	7,945.-
▶ 56	78	9	8,674.-
▶ 57	49	9	8,674.-
▶ 58	50	9	8,674.-
▶ 59	51	9	8,674.-
▶ 60	52	9	8,674.-
▶ 61	53	9	9,840.-
▶ 62	54	9	9,840.-
▶ 63	55	9	9,840.-
▶ 64	56	9	9,840.-
▶ 65	57	9	9,840.-

▶ มีสินค้า

D : เส้นผ่านศูนย์กลางวงใน d : เส้นผ่านศูนย์กลางวงนอก

Z : จำนวนร่องฟัน

- Universal shank for various magnetic drills.
- Selected special-purpose carbide tips with multi-cut geometry for ply-cutting and lower friction. Reduced damage of tips and improved performance of chips removal
- Applicable to hole cutting and process of annular groove on various magnetic drill and press

### Suitable pins

Type	Size	Matching Cutter	Price
DPB	8x130	18mm-60mm	500.-
DPT	8x130	18mm-60mm	



T.C.T annular cutter with Universal shank

TC สำหรับ Diameter ไม่เกิน 60 mm

ตัวพินที่เป็นคาร์ไบด์  
ผลิตโดยบริษัท SANDVIK  
จากประเทศสวีเดน  
เป็นคาร์ไบด์ที่ดีที่สุดในโลก



# JET BROACH

ที่คุณภาพดีที่สุดในโลก  
The best quality in the world



## DNTC-100

Tolerance 0.0001 mm.

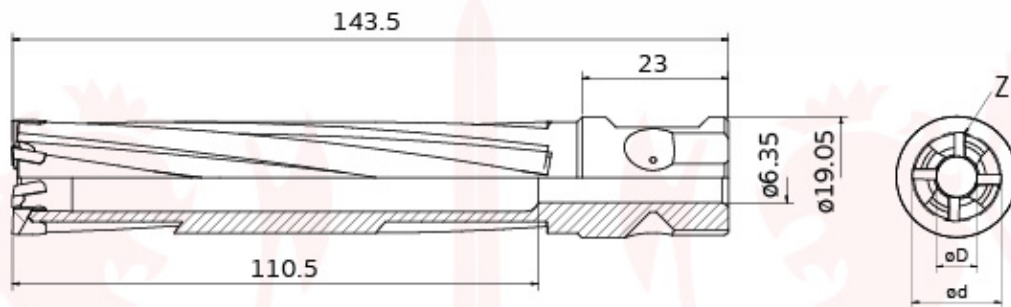

d(mm)	D(mm)	Z	Price
14	6.5	4	4,414.-
15	7.5	4	4,414.-
▶ 16	8	4	4,414.-
17	9	4	4,414.-

▶ มีสินค้า

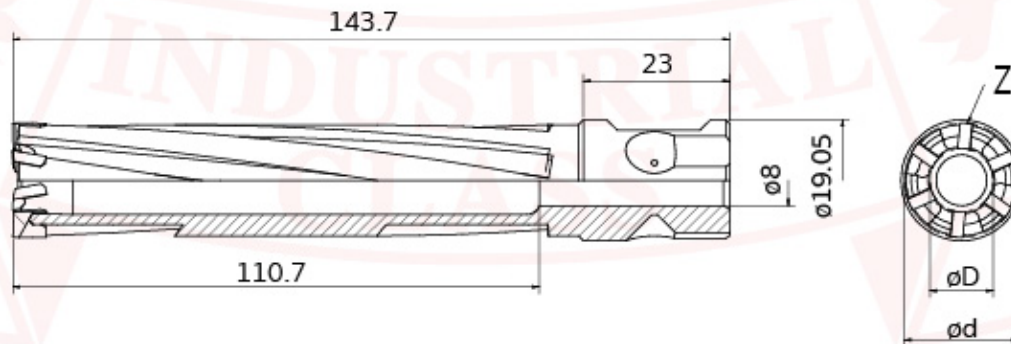

d(mm)	D(mm)	Z	Price
18	10	6	4,414.-
19	11	6	4,414.-

D : เส้นผ่านศูนย์กลางวงใน d : เส้นผ่านศูนย์กลางวงนอก  
Z : จำนวนร่องพิน

- Universal shank for various magnetic drills.
- Selected special-purpose carbide tips with multi-cut geometry for ply-cutting and lower friction. Reduced damage of tips and improved performance of chips removal
- Applicable to hole cutting and process of annular groove on various magnetic drill and press

Suitable pins

Type	Size	Matching Cutter	Price
▶ DPC	8x160	18mm-60mm	630.-
DPT	8x157	18mm-60mm	



T.C.T annular cutter with Univers  
TC สำหรับ Diameter ไม่เกิน 60 mm

ตัวพิมพ์เป็นคาร์ไบด์  
ผลิตโดยบริษัท SANDVIK  
จากประเทศสวีเดน  
เป็นคาร์ไบด์ที่ดีที่สุดในโลก



# JET BROACH

ที่คุณภาพดีที่สุดในโลก  
The best quality in the world



## DNTC-100

Tolerance 0.0001 mm.

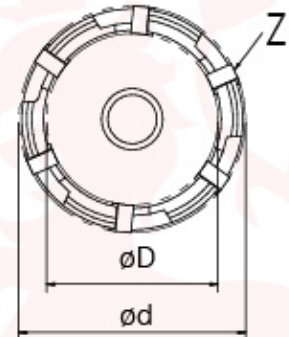
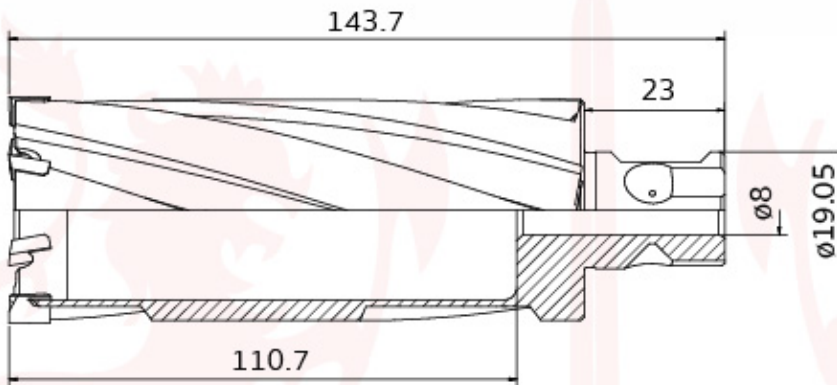

d(mm)	D(mm)	Z	Price
▶ 20	12	6	4,414.-
21	13	6	4,414.-
▶ 22	14	6	4,414.-
23	15	6	4,414.-
▶ 24	16	6	4,414.-
25	17	6	4,414.-
▶ 26	18	6	4,909.-
27	19	6	4,909.-
▶ 28	20	6	4,909.-
29	21	6	4,909.-
30	22	6	4,909.-
31	23	6	5,647.-
32	24	6	5,647.-
▶ 33	25	6	5,647.-
34	26	6	5,647.-
▶ 35	27	6	5,647.-
▶ 36	28	6	6,515.-
▶ 37	29	6	6,515.-
38	30	6	6,515.-
39	31	6	6,515.-
▶ 40	32	6	6,515.-
41	33	6	7,507.-
42	34	6	7,507.-
43	35	6	7,507.-
44	36	6	7,507.-
45	37	6	7,507.-

▶ มีสินค้า

D : เส้นผ่านศูนย์กลางวงใน d : เส้นผ่านศูนย์กลางวงนอก

Z : จำนวนร่องฟัน

- Universal shank for various magnetic drills.
- Selected special-purpose carbide tips with multi-cut geometry for ply-cutting and lower friction. Reduced damage of tips and improved performance of chips removal
- Applicable to hole cutting and process of annular groove on various magnetic drill and press

### Suitable pins

Type	Size	Matching Cutter	Price
▶ DPC	8x160	18mm-60mm	630.-
DPT	8x157	18mm-60mm	



T.C.T annular cutter with Universal shank  
 TC สำหรับ Diameter ไม่เกิน 60 mm

ตัวพิมพ์เป็นคาร์ไบด์  
 ผลิตโดยบริษัท SANDVIK  
 จากประเทศสวีเดน  
 เป็นคาร์ไบด์ที่ดีที่สุดในโลก



# JET BROACH

ที่คุณภาพดีที่สุดในโลก  
 The best quality in the world



## DNTC-100

Tolerance 0.0001 mm.

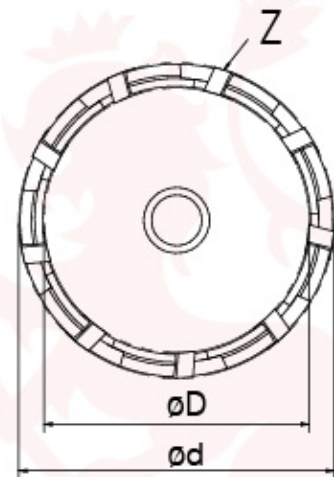
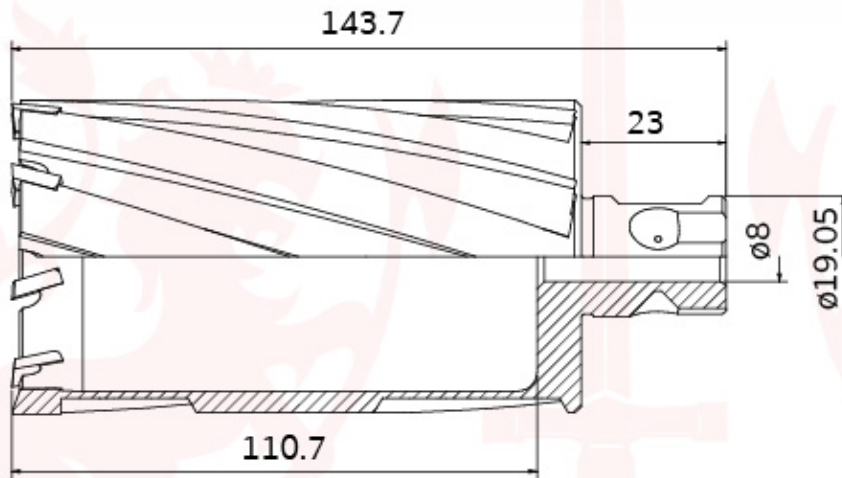

d(mm)	D(mm)	Z	Price
46	38	9	8,940.-
47	39	9	8,940.-
48	40	9	8,940.-
49	41	9	8,940.-
50	42	9	8,940.-
51	43	9	10,070.-
52	44	9	10,070.-
53	45	9	10,070.-
54	46	9	10,070.-
55	47	9	10,070.-
56	48	9	10,994.-
57	49	9	10,994.-
58	50	9	10,994.-
59	51	9	10,994.-
60	52	9	10,994.-
61	53	9	XX,XXX.-
62	54	9	XX,XXX.-
63	55	9	XX,XXX.-
64	56	9	XX,XXX.-
65	57	9	XX,XXX.-

D : เส้นผ่านศูนย์กลางวงใน d : เส้นผ่านศูนย์กลางวงนอก

Z : จำนวนร่องฟัน

- Universal shank for various magnetic drills.
- Selected special-purpose carbide tips with multi-cut geometry for ply-cutting and lower friction. Reduced damage of tips and improved performance of chips removal
- Applicable to hole cutting and process of annular groove on various magnetic drill and press

### Suitable pins

Type	Size	Matching Cutter	Price
DPC	8x160	18mm-60mm	630.-
DPT	8x157	18mm-60mm	



# Rail cutter range

ตัวฟันที่เป็นคาร์ไบด์  
ผลิตโดยบริษัท SANDVIK  
จากประเทศสวีเดน  
เป็นคาร์ไบด์ที่ดีที่สุดในโลก



## JET BROACH

**ที่คุณภาพดีที่สุดในโลก**  
**The best quality in the world**



สำหรับงาน  
เจาะรางรถไฟ

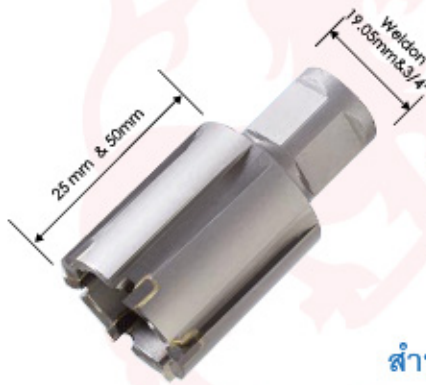

**DRTX-25**

3/4" weldon shank  
Tolerance 0.0001 mm.

สำหรับเจาะรางธรรมดา



**DRSX-25**

3/4" weldon shank  
Tolerance 0.0001 mm.

สำหรับเจาะรางที่มีความเหนียว  
เป็นพิเศษและรางที่มีแมงกานีส

Diameter		Price
MM	Inch	
18		
19	3/4"	
20		
21	13/16"	
22	7/8"	
23		
24	15/16"	
25	1"	
26		
27	1-1/16"	

Diameter		Price
MM	Inch	
27.5		
28		
29	1-1/8"	
30	1-3/16"	
31		
32	1-1/4"	
33	1-5/16"	
34		
35	1-3/8"	
36		

\*หมายเหตุ ▶ คือ มีสินค้า  
▶ คือ Pre-Order

○Made of speical carbide tips, superiorly--designed geometry for better endurance  
○Applicable to hole cutting on railtrack, like PD3.

Suitable pins

Type	Size	Matching Cutter	Price
DPB	6.34/5.3x77	(12~17)x25 mm.	
DPB	7.98x77	(18~36)x25 mm.	
DPB	7.98x103	(18~36)x50 mm.	

Diameter		Price
MM	Inch	
18		
19	3/4"	
20		
21	13/16"	
22	7/8"	
23		
24	15/16"	
25	1"	
26		
27	1-1/16"	

Diameter		Price
MM	Inch	
27.5		
28		
29	1-1/8"	
30	1-3/16"	
31		
32	1-1/4"	
33	1-5/16"	
34		
35	1-3/8"	
36		

\*หมายเหตุ ▶ คือ มีสินค้า

○Select of high performance solid carbide tips, superiorly--designed geometry for the best holes drilling performance;  
○Applicable to high Si and high tough rail tracks .

Suitable pins

Type	Size	Matching Cutter	Price
DPB	7.98x77	(18~36)x25 mm.	



# Rail cutter range

ตัวฟันที่เป็นคาร์ไบด์  
ผลิตโดยบริษัท SANDVIK  
จากประเทศสวีเดน  
เป็นคาร์ไบด์ที่ดีที่สุดในโลก



## JET BROACH

คุณภาพดีที่สุดในโลก  
The best quality in the world



สำหรับงาน  
เจาะรางรถไฟ

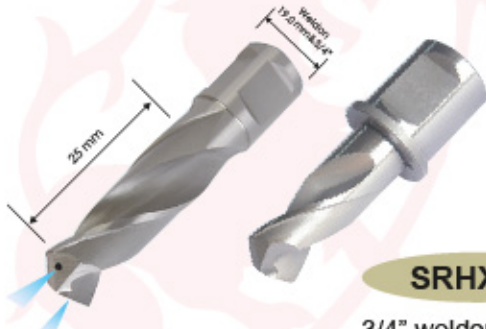

**SRHX-25**

3/4" weldon shank  
Tolerance 0.0001 mm.

Diameter		
MM	Inch	Price
6		
8		
9.8		
10		
11		
12		
13.5		
14		
15		
16		
17		
18		

Diameter		
MM	Inch	Price
19	3/4"	
20		
21	13/16"	
22	7/8"	
23		
24	15/16"	
25	1"	
26		
27	1-1/16"	
27.5		
28		

\* หมายถึง ■ คือ Pre-Order  
ไม่ใช่ Pilot Pin

○ Made of speical carbide tips, superiorly-designed geometry for better endurance.  
○ Applicable to hole cutting on railtrack, like PD3 .



**SKSY-25**

..... shank  
Tolerance 0.0001 mm.

Diameter		
MM	Inch	Price
6		
8		
9.8		
10		
11		
12		
13.5		
14		
15		
16		
17		
18		
19	3/4"	
20		
21	13/16"	
22	7/8"	

Diameter		
MM	Inch	Price
23		
24	15/16"	
25	1"	
26		
27	1-1/16"	
27.5		
28		
29	1-1/8"	
30	1-3/16"	
31		
32	1-1/4"	
33	1-5/16"	
34		
35	1-3/8"	
36		

\* หมายถึง ■ คือ Pre-Order  
ไม่ใช่ Pilot Pin

○ New rail cutter. Angels of carbide tips adjustable. Carbide tips exchangeable;  
○ Suitable on stable rail drills and machines.



# Accessories of annular cutter

## Pilot pin

1. Accessories include pilot pin, arbor and adater.
2. Professionally design and manufacture for quality and practical applications.
3. Various types for all applications.
4. Special arbors are available.

\*หมายเหตุ ▶ คือ มีสินค้า



Type	Size	Matching Cutter	Price
▶ DPB	6.34x90	DNTC-35 (12-17 mm.)	<b>240.-</b>
▶ DPB	6.34x106	DNTC-50 (12-17 mm.)	<b>280.-</b>



Type	Size	Matching Cutter	Price
▶ DPB	8.00x90	DNTC-35 (18-60 mm.)	<b>240.-</b>
▶ DPB	8.00x105	DNTC-50 (18-60 mm.)	<b>280.-</b>
▶ DPB	8.00x115	DNTC-50 (≥60 mm.)	<b>300.-</b>
▶ DPB	8.00x130	DNTC-75 (18-60 mm.)	<b>500.-</b>
▶ DPB	8.00x145	DNTC-75 (18-60 mm.)	<b>550.-</b>



Type	Size	Matching Cutter	Price
▶ DPC	8x130	DNTC-75 (18-60 mm.)	<b>500.-</b>
▶ DPC	8x160	DNTC-100 (18-60 mm.)	<b>630.-</b>