



เครื่องตัดพลาสมา

PLASMA CUTTING MACHINE

CUT40 LED

ตัดนิ่มและคม รอยตัดสวย

ขุมพลังใหม่ด้วยระบบ

INTELLIGENT

MICROPROCESSOR CONTROL
Designed in THAILAND



ตัดเหล็ก **15 มม.**
หนาสุดถึง (ตัดสวยที่ 7 มม.)**

ลักษณะการใช้งาน	วัสดุ	ขนาด(มม.)
การตัดขาด	เหล็ก	12
	อลูมิเนียม	6
การตัดสวย	เหล็ก	6
	อลูมิเนียม	4
การเจาะ	เหล็ก	2
	อลูมิเนียม	



- มีระบบปล่อยน้ำที่ออกจากกรองลม เมื่อหยุดใช้งาน
- ระบบหน่วงลม (Air delay) ช่วยระบบความร้อนหัวตัด ยืดอายุการใช้งาน
- กรองลมและเกจปรับแรงดันลมในตัว สะดวกในการใช้งาน

17,500.-/Pc
1Pc/Carton

ใช้กับไฟฟ้า 220V ประหยัดไฟ ใช้กับไฟบ้านได้

*ใช้ปริมาณลมที่ 180 ลิตร/นาที

Specification

Input voltage (V)	AC220V±10%
Rate input current (A)	31
No-load voltage (V)	290
Current Range (A)	20-40
Rate output voltage (V)	88-96
Duty cycle (%)	30
Efficiency (%)	77
Power factor	0.73
Insulation Class	H
Housing Protection Class	IP21S
Arcing Way	Touch
Pressure of air compressor (MPa)	0.3-0.45
Nozzle Inside Hole (mm)	0.9
Thickness (mm)	1-18
Grid Cutting	YES
Rated power	6.8
Weight (kg)	6.1
Machine Dimensions (mm)	455X150X280

อุปกรณ์มาตรฐาน (Standard Accessories)

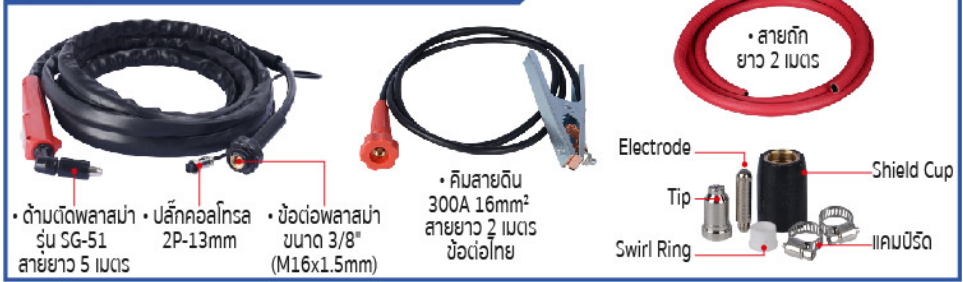

วิธีใช้ : สำหรับตัดพลาสมา

ข้อแนะนำ : ต่อกับบีมลมเท่านั้น ห้ามต่อกับถังลม กรณีต้องการต่อสายไฟควรต่อกับพาวเวอร์ปลั๊กและสายไฟ ขนาด 2.5 sq.mm.



ขึ้นไปและใช้งานร่วมกับบีมลมซูโม่เพื่อประสิทธิภาพสูงที่สุดในการตัด

คำเตือน : เพื่อความปลอดภัยสวมอุปกรณ์ป้องกัน ทุกครั้งก่อนการใช้งาน



สามารถตัดให้ขาดได้ที่
ความหนาสูงสุด 20 mm
และตัดได้สวยที่ความหนา
ประมาณ 10 mm
*ใช้ปริมาณลมที่ 110 ลิตร/นาที



ไม่แถม
หัวปลั๊ก

สายไฟ
ยาว 270 cm

Full Power
Mosfet Low Cost Maintenance

เครื่องตัดพลาสมา
ระบบ
INVERTER

32,000.-/Pc
1Pc/Carton



สามารถตัดชิ้นงานต่างๆ ได้อย่างง่ายดาย รวดเร็ว
ชิ้นงานที่ตัดเรียบเนียนสวยโดยไม่จำเป็นต้องตกแต่ง
เพิ่มเติมให้เสียเวลาและมีระบบการทำงานที่ออกแบบมา
ให้ใช้งานโดยไม่ต้องเปลี่ยนหัวตัดบ่อย

TECHNICAL DATA

V_{IN} แรงดันไฟฟ้า Power Voltage (v) 1 Phase / AC220V ± 15%	P_{IN} กระแสไฟ Rated input power (KVA) 10.1KVA	F Class of Insulation
V_{out} แรงดันไฟในการทำงาน Rated output voltage 104V	V_o แรงดันไฟขณะไร้ภาระ No-load voltage 254 V	H ขนาดเครื่อง Dimensions (mm.) 480x204x303
A_{IN} กำลังไฟ Rated input current (A) 43.7A	Input Frequency ความถี่ Frequency (Hz) 50 Hz	IP ระดับป้องกัน Protection grade IP21
I₂ Current range กระแสไฟในการทำงาน Rated output current 60A	η ประสิทธิภาพ Efficiency 80%	Weight น้ำหนัก Weight (kg.) 19 kg
DUTY CYCLE ความสามารถในการทำงาน Duty Cycle 60%	φ พาวเวอร์แฟกเตอร์ Power Factor 0.73	

Pilot arc model HF oscillating
Pressure of air compressor 4-5 kg
Thickness 1-20 mm
ระบบระบายความร้อน Air cool

อุปกรณ์มาตรฐาน (Standard Accessories)



ข้อแนะนำ : เพื่อประสิทธิภาพสูงสุดควรต่อกับสายไฟขนาด 4.0sqmm ขึ้นไป และใช้กับปั๊มลมซูโม่

ตัดนิ่มและคม
รอยตัดสวย

SMART
IGBT INVERTER

ตัดเหล็ก
หนาสุดถึง **35 มม.**
(ตัดสวยที่ 16 มม.)**



ข้อแนะนำ : เพื่อประสิทธิภาพสูงสุด ควรต่อกับสายไฟ
ขนาด 2.5 mm² ขึ้นไปและใช้กับปั๊มลมซูโม่

⚠ คำเตือน : ห้ามใช้กับถังออกซิเจน

65,000.-/Pc
1Pc/Carton

อุปกรณ์มาตรฐาน (Standard Accessories)



• ชุดตัดพลาสมา (Plasma torch)



• คีมสายดิน 300A 16mm²
สายยาว 2 เมตร ข้อต่อไทย
(Earth Clamp)



• สายทึบ PVC
(PVC Hose)



• โถงจักรกลม
(Air Compression
Release Valve)



• เต้าเสียบแบบพาวเวอร์ปลั๊ก
(Power Plug)

***ใช้ปริมาณลมที่ 150 ลิตร/นาที**

Specification

Power voltage (V)	AC380V±15%
Frequency (Hz)	50
Rated input current (A)	17
No-load voltage (V)	287
Output current regulation (A)	30-100
Rated output voltage (V)	120
Duty cycle (%)	60
No-load loss (W)	40
Efficiency (%)	85
Power factor	0.93
Insulation grade	F
Housing protection grade	IP21
ARC starting Manner	No Contact
Pressure of air compressor (Kg)	5-6
Thickness of workpiece	MAX. 45mm
Net weight (kg)	19.3
Dimensions (mm)	515x260x480



สายตัดพลาสมา

PLASMA CUTTING TORCHES

SG-51 JW-40

คุณสมบัติ

- ขนาดสาย 5 mm² สายยาว 5 ม.
- ตัดชิ้นงานได้สวย 1-5 มม.
- สามารถตัดชิ้นงานหนาสูงสุด 20 มม.
- ขั้วต่อพลาสมา 3/8"
- ใช้งานกับเครื่องตัดพลาสมา Cut-40

ขั้วต่อ สวิตซ์



ขั้วต่อลม



สายยาว
5 เมตร



1,800.-/Pc
1 Pc/ctn

TECHNICAL DATA

TYPE OF COOLING	Air Cooled
PILOT CURRENT	50Amps
DUTY CYCLE	60%
TYPE OF GAS	Air
WORKING PRESSURE	4.5-5.5Bar
TYPE OF IGNITION	HF
GAS SUPPLY	Air Compressor
CUTTING THICKNESS	20 mm
CABLE SIZE	5 mm ² x5m
WEIGHT	1.6 kg





สายตัดพลาสมา

PLASMA CUTTING TORCHES

SG-51 JW-40

Accessories

Unit : mm

▶ = มีสินค้า



▶ Electrode SG-51/JW-40

65.-/Pc

Pack	Box	Ctn
ชิ้น/แพ็ค	ชิ้น/กล่อง	ชิ้น/ลัง
10	200	1000



.....g

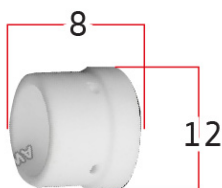

▶ Swirl Ring SG-51/JW-40

20.-/Pc

Pack	Box	Ctn
ชิ้น/แพ็ค	ชิ้น/กล่อง	ชิ้น/ลัง
10	-	2500



.....g



▶ Shield Cup SG-51/JW-40

160.-/Pc

Pack	Box	Ctn
ชิ้น/แพ็ค	ชิ้น/กล่อง	ชิ้น/ลัง
1	50	-



.....g

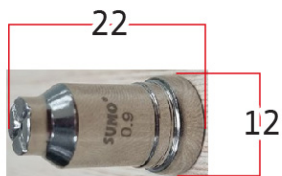

▶ Tip 0.9 mm 30A SG-51/JW-40

60.-/Pc

Pack	Box	Ctn
ชิ้น/แพ็ค	ชิ้น/กล่อง	ชิ้น/ลัง
10	100	1200



.....g

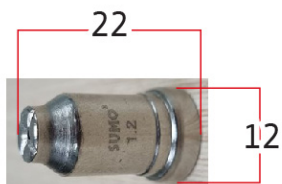

▶ Tip 1.2 mm 50A SG-51/JW-40

60.-/Pc

Pack	Box	Ctn
ชิ้น/แพ็ค	ชิ้น/กล่อง	ชิ้น/ลัง
10	100	1000



.....g



▶ ด้ามตัดพลาสมา

SG-51/JW-40 (พร้อมสวิตช์)

900.-/Pc

Pack	Box	Ctn
ด้าม/แพ็ค	ด้าม/กล่อง	ด้าม/ลัง
1	-	40



.....g

TAIWAN Plasma Torch SG-51



100.-
Switch Plasma 16x16mm
for SG-51/PT-31
Lot 100136108053032

ITEM	DESCRIPTION	USSQ (แพ็ค/กล่อง/ลัง)	LOT	Price
1	Electrode	10/200/2400	051136018054021	65.-
2	Swirl Ring	20/200/2400	061836018054015	20.-
3	Tip 0.9mm (30A)	10/100/1200	071036018053022	60.-
	Tip 1.2mm (50A)	10/100/1200	051136018054022	60.-
4	Shield cup	1/50/-	020836018054031	160.-
5	Torch Head	1/-/40	050936018050030	900.-
	Torch Head (switch)	1/-/40	100136018053025	900.-
6	Complete Set	1/-/5	062436018054034	1800.-

TAIWAN Plasma Torch SG-53



ITEM	DESCRIPTION	USSQ (แพ็ค/กล่อง/ลัง)	LOT	Price
1	Electrode	20/200/2400	041640018052035	60.-
2	Tip 1.1mm 40A	20/160/1920	041640018052028	70.-
3	Shield Cup	5/-/-	071440018052027	40.-
4	Torch Head	1/-/50	071440018052047	950.-

TAIWAN Plasma Torch SG-55/AG-60



ITEM	DESCRIPTION	USSQ (แพ็ค/กล่อง)	LOT	Price
1	Electrode	10/200	100136018053034	45.-
2	Tip 1.1mm	10/100	100136018053030	50.-
3	Shield cup	10	111740018051027	30.-
4	Torch AG-60			

TAIWAN Plasma Torch SP60



ITEM	DESCRIPTION	USSQ (แพ็ค)	LOT	Price
1	Electrode	10	072236018054035	50.-
2	Tip 1.2mm	10	072236018054035	50.-
3	Shield cup	10	122136018052035	30.-
4	Torch SP60			

THAILAND Plasma Torch SPC-50



ITEM	DESCRIPTION	USSQ (แพ็ค)	LOT	Price
1	Electrode	20	061835018054030	50.-
2	Gas Diffuser	50	041640018052040	10.-
3	Tip 1.2mm	10	061835018054037	40.-
	Tip 1.5mm	40	041640018052040	40.-
4	Shield cup	10	042240018053041	130.-
5	Torch Head	1	041640018052040	650.-

SAF Plasma Torch CP-40R / CR-100R

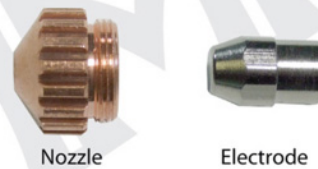

ITEM	DESCRIPTION	USSQ (แพ็ค/กล่อง/ลัง)	LOT	Price
1	Electrode	10/50/600	043040018052040	60.-
2	Nozzle 1.2mm	10/50/600	043040018052040	70.-
	Nozzle 1.6mm	10/50/600	043040018052040	70.-

CEBORA Plasma Torch P-70

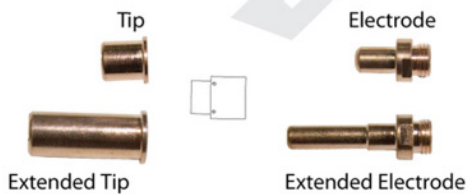

ITEM	DESCRIPTION	USSQ (แพ็ค/กล่อง/ลัง)	LOT	Price
1	Electrode	10/100/1200	042936018052018	75.-
2	Extended Electrode	10	071740018052025	90.-
3	Tip 1.2mm	10/100/1200	042936018052018	65.-
4	Extended Tip 1.2mm	10	071740018052026	75.-

CEBORA Plasma Torch P-150

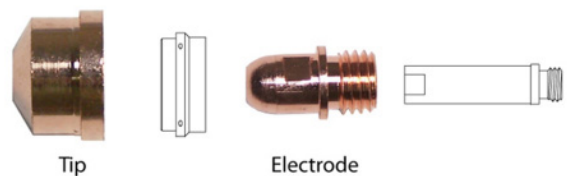

ITEM	DESCRIPTION	USSQ (แพ็ค/กล่อง)	LOT	Price
1	Electrode	10/200	021540018051033	85.-
2	Tip	10/100	021540018051035	90.-

OTC Plasma Torch M3000



ITEM	DESCRIPTION	P/B	LOT	Price
1	Electrode - HF	10/200	091840018051038	75.-
2	Tip 1.0mm	10/200	091840018051040	70.-
3	Shield cup	10	110640018052035	60

OTC Plasma Torch D7000



ITEM	DESCRIPTION	P/B	LOT	Price
1	Electrode	10/250	091840018051039	75.-
2	Tip 1.0mm	10/100	091840018051039	75.-
3	Shield Cup	10	110640018052032	65.-

OTC Plasma Torch D12000



ITEM	DESCRIPTION	P/B	LOT	Price
1	Electrode	10/100	120740018052055	75.-
2	Tip 1.3mm	10/100	120740018052033	75.-
	Tip 1.6mm	10/100	120740018052033	75.-
3	Shield cup	10	110640018052030	70.-

ESAB Plasma Torch PT-31, JG-40

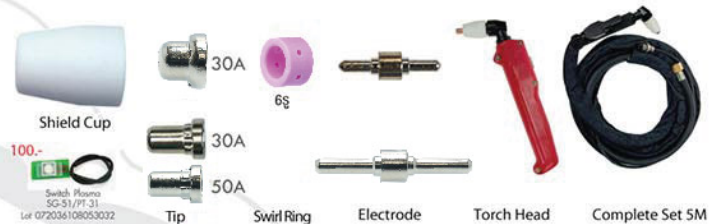

ITEM	DESCRIPTION	CODE	P / B / C	PRICE
1	Electrode (short)	18205	50/500/6000	20.-
	Electrode (long)	19683	10/200/2400	45.-
2	Swirl Ring 6 hole	18785	50/500/6000	10.-
3	Tip 30A (short)	18866	20/300/3600	20.-
	Tip 0.9 mm PT-31/JG-40 (Long) 30A	19682	50/200/2400	30.-
	Tip 1.2mm PT-31/JG-40 (Long) 50A	20079		30.-
4	Shield cup	18844	10/-/-	25.-
5	Torch Head		1/-/50	600.-
6	Complete Set (5M)		1/-/5	2,000.-

ESAB Plasma Torch PT-41, ME-50, SP-50, P-50



ITEM	DESCRIPTION	P	LOT	Price
1	Electrode	10	122140018050035	60.-
2	Swirl Ring	20	032940018051043	25.-
3	Tip 1.0mm	10	122740018050038	40.-
4	Shield cup	10	122140018050035	35.-

ESAB Plasma Torch PT-51 ; JG-50 ; SP-40



ITEM	DESCRIPTION	P	LOT	Price
1	Electrode	10	062436018054025	50.-
2	Swirl Ring	50	080540018050016	20.-
3	Tip	10	062436018054043	30.-
4	Shield cup	10	033140018053025	35.-
5	Torch Head	1	080540018050040	700.-

THERMAL DYNAMIC PCH-25



ITEM	DESCRIPTION	P/B/C	LOT	Price
1	Electrode	10/200/-	013140018052035	40.-
2	Swirl Ring	50/-/-	013140018052040	40.-
3	Tip	20/200/-	122440018052040	40.-

THERMAL DYNAMIC PCH-35

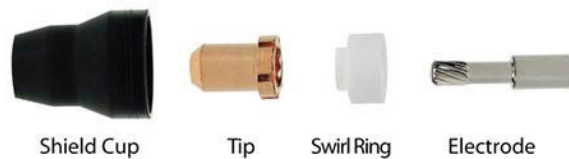

ITEM	DESCRIPTION	P/B/C	LOT	Price
1	Electrode	10/200/-	013140018052052	40.-
2	Swirl Ring	20/300/-	013140018052023	35.-
3	Tip	10/200/-	013140018052035	40.-
4	Shield cup	1/20/120	082540018050044	200.-
5	Torch Head	1/-/50	050940018050040	1,500.-

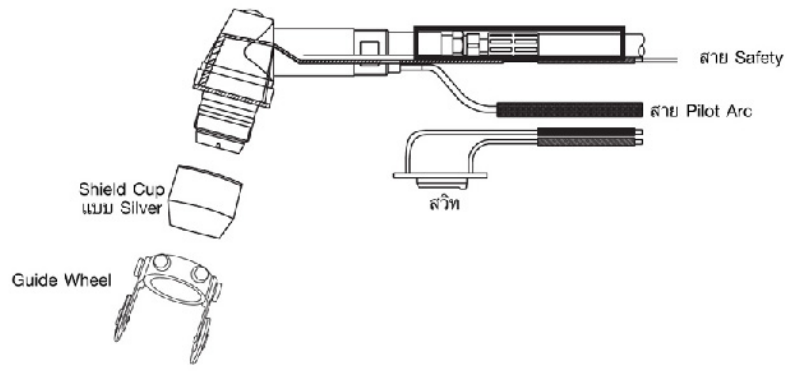

2) Torch Body Safety
เกล็ดขาวใน 3) Torch Body Straight



12.1) Complete Set 5m



12.2) Complete Set Safety System (5m)

8) Rear Connector P80 M8x0.75mm 9) Adapter P-80 3/8"x24,8 x 0.75mm PANA 10) Nipple เกล็ดขาวใน P-80 3/8"x24,8x0.75mm PANA 20x24mm 11.1) Switch Plasma 20x24mm 11.2) Switch (new generation)

ITEM	DESCRIPTION	US\$จ	LOT	Price
1	Torch Body	1P, 50C	050840018050042	2,400.-
2	Torch Body Safety	1P, 50C	073136018053032	2,100.-
3	Torch Body Straight	1P	102140018051040	2,400.-
4	Electorde	1P, 100B, 1200C	072236018054035	70.-
5.1	Tip 1.3mm	10P, 50B, 600C	042940018052033	60.-
	Tip 1.5mm	10P, 50B, 600C	072236018054040	60.-
5.2	Tip 1.3mm (Sunshine)	10P, 50B	042940018052028	70.-
	Tip 1.5mm (Sunshine)	10P, 50B	042940018052028	70.-
6.1	Shield Cup	10P, 360C	013040018052044	30.-
6.2	Shield Cup (Silver)	10P	122940018049038	50.-
7	Guiude Wheel	10P, 100C	062436018054028	260.-
8	Rear Connector 8x0.75mm	10P, 100C	061836108054085	50.-
9	Adapter P-80 3/8"x24,8 x 0.75mm PANA			230.-
10	Nipple เกล็ดขาวใน P-80 3/8"x24,8x0.75mm PANA		061836108054004	230.-
11.1	Switch Plasma 20x24mm		072036108053032	100.-
11.2	Switch (new generation)			
12.1	Complete Set 5M		072236018054035	3,600.-
12.2	Complete Set Safety System 5M		011936018053043	4,200.-

P-160 สำหรับ PANASONIC

NEW



ITEM	DESCRIPTION	P/ B/ C	LOT	Price
1	Electrode		021640018051040	70.-
2	Tip		021640018051046	70.-
3	Shield cup	10	021640018051040	70.-
4	Complete Set		021640018051040	9,300.-

G-160 สำหรับ PACIFIC

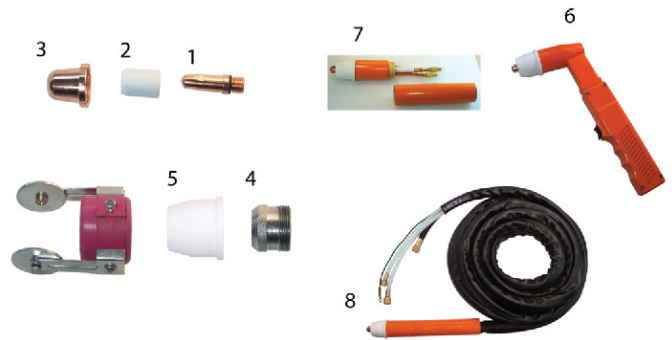

ITEM	DESCRIPTION	P/ B/ C	LOT	Price
1	Electrode	10/100	091840018051040	70.-
2	Swirl Baffle		091840018051040	35.-
3	Tip 2.0mm	10/100	091840018051040	70.-
4	Tip Cap	5/25/300	091840018051040	80.-
5	Shield cup	5	091840018051040	70.-
6	Torch Head	1	091740018051040	3,400.-
7	Torch Head (Pen)	1	091840018051040	3,400.-
8	Complete set (pen)	1/-/5	091840018051040	9,300.-

S-45 สำหรับ TRAFIMET



ITEM	DESCRIPTION	P/ B/ C	LOT	Price
1	Electrode	10/100	052740018052028	85.-
2	Gas Diffuser	1	0111701007554100	320.-
3	Nozzle 1.0mm	10/100	052740018052027	65.-
4	Shield cup	1/20/120	052740018052019	480.-
5	Torch Head	1	120440018051040	2,000.-

KJ-200

NEW

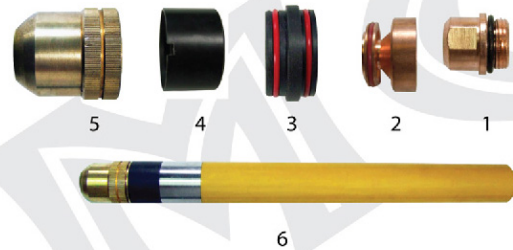

ITEM	DESCRIPTION	P/ B/ C	LOT	Price
1	Electrode	1/10/100	052740018052040	900.-
2	Nozzle, 2.4mm (160A)	1/5/50	052740018052040	650.-
	Nozzle, 2.8mm (250A)	1/5/50	052740018052040	650.-
3	Swirl Ring		052740018052036	1,200.-
4	Water Ring		052740018052038	900.-
5	Retaining Cap		052740018052040	1,350.-
6	Torch Head (Pen)		052736018005084	20,000.-

For Hypertherm PMX30



ITEM	DESCRIPTION	Pcs/pack	LOT	Price
1	220478 Electrode	5	011136018054030	250.-
2	220480 Nozzle	5	011136018054037	140.-

for Hypertherm MAX20



ITEM	DESCRIPTION	Pcs/pack	LOT	Price
1	020382 Electrode	10	062040018052012	250.-
2	120504 Nozzle	10	090940018051019	140.-

for Hypertherm MAX100



ITEM	DESCRIPTION	Pcs/pack	LOT	Price
1	120433 Electrode	10	062040018052016	390.-
2	020337 Nozzle	10	062040018052023	210.-

for Hypertherm PMX600/800/900



ITEM	DESCRIPTION	Pcs/pack/Ctn	LOT	Price
1	120573 Electrode	5	062036018052019	390.-
2	120826 Nozzle	10/500	082740018052022	160.-
3	120577 Nozzle	10/500	062040018052021	160.-
4	120828 Shield	10	062036018052014	780.-

for Hypertherm PMX1000/1250

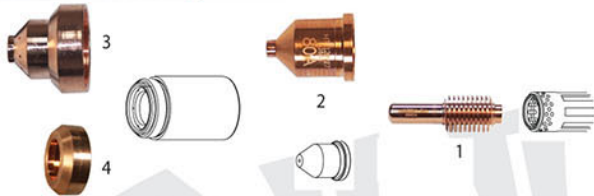

ITEM	DESCRIPTION	Pcs/pack/Ctn	LOT	Price
1	120926 Electrode	10/-	062036018052019	390.-
2	120927 Nozzle	10/500	062040018052017	290.-
3	120929 Shield (hand)		062036018052019	690.-
	120930 Shield(Machine)	5/200	062040018052005	950.-
4	120979 Deflector	1/-	062036018052016	480.-

for Hypertherm PMX1650



ITEM	DESCRIPTION	Pcs/pack/Ctn	LOT	Price
1	220037 Electrode	10/500	062040018052031	400.-
2	220011 Nozzle	10/500	062040018052017	290.-
2.1	220329 Nozzle(finecut)	5/-	011136018054018	290.-
3	220047 Shield	5/200	062040018052022	740.-

for Hypertherm MAX200



ITEM	DESCRIPTION	Pcs/pack/Ctn	LOT	Price
1	220021 Electrode	10	062036018052018	850.-
2	020607 Swirl Ring	10	062040018052010	1,300.-
3	020608 Nozzle	5/250	062040018052060	350.-
4	020424 Shield	4/100	062040018052022	1,250.-



อะไหล่ตามตัดพลาสมา

PLASMA TORCH PARTS

PT-40-60

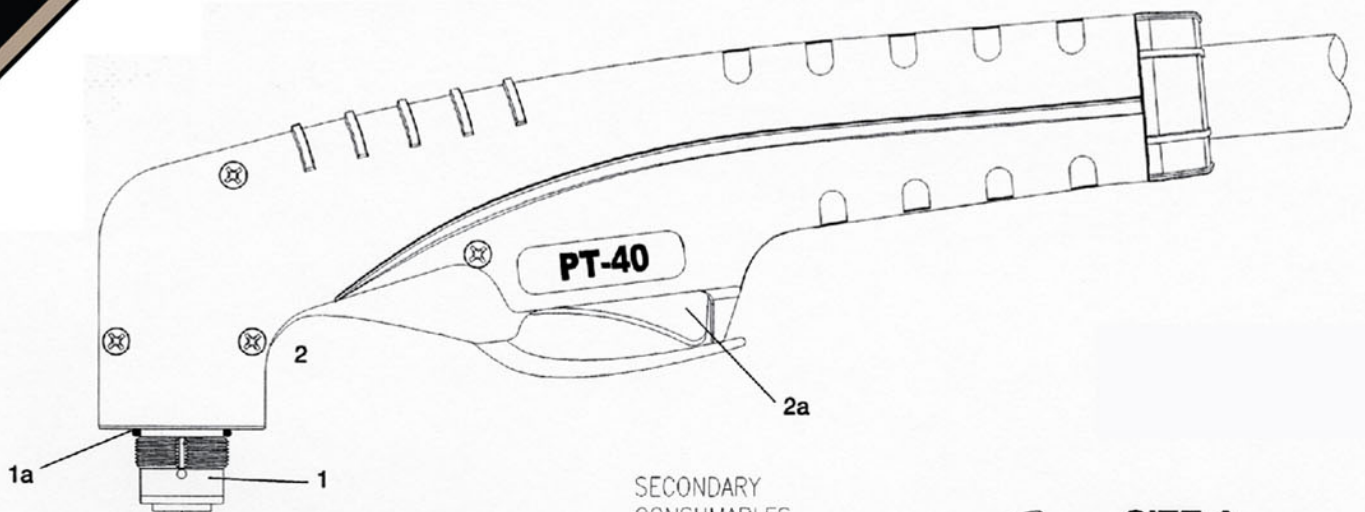

SECONDARY CONSUMABLES

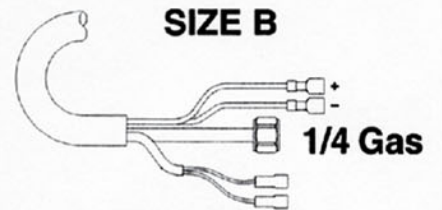
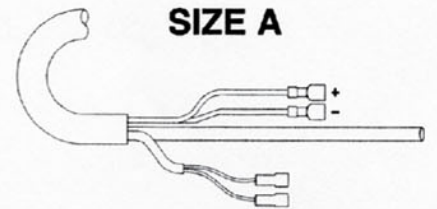
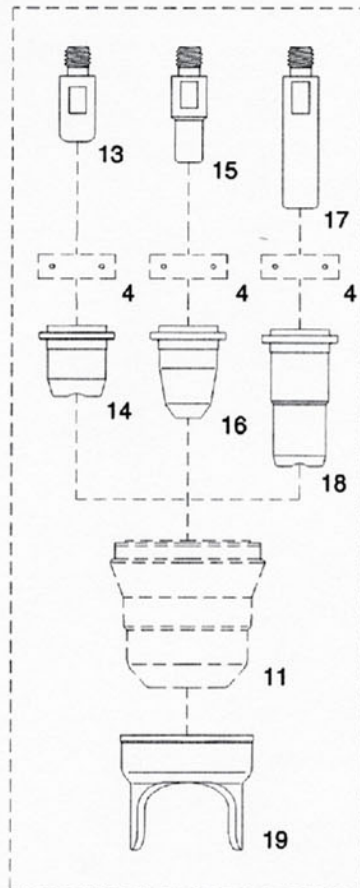
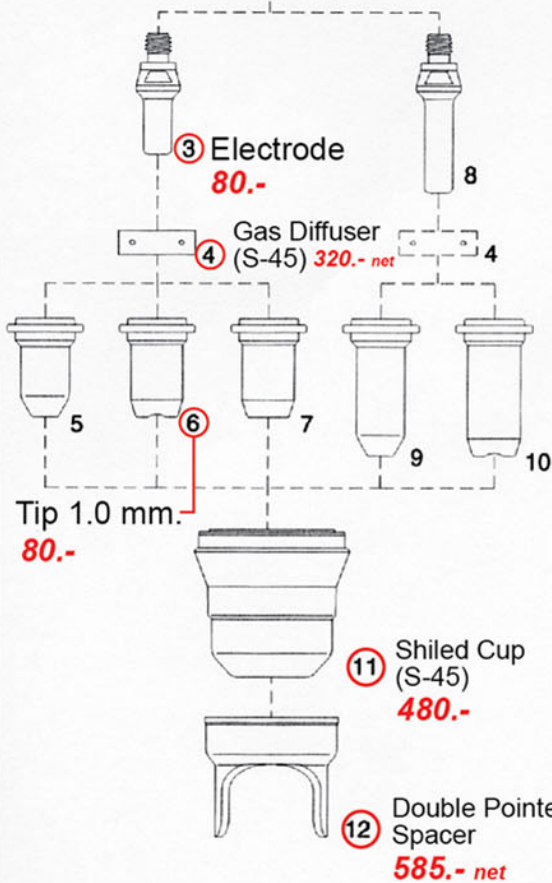



อะไหล่ด้านตัดพลาสมา

PLASMA TORCH PARTS

PT-40-60

ITEM	DESCRIPTION	PRICE
1	PT-40 70° TORCH HEAD	
1a	O-RING	
2	HANDLE WITH SWITCH	
2a	SWITCH	
3	ELECTRODE BACK STRIKING	80.-
4	GAS DIFFUSER (S-45)	320.- net
5	TIP CONTACT CUTTING Ø0.65 10-20A BACK STRIKING	
	TIP CONTACT CUTTING Ø0.8 20-30A BACK STRIKING	
	TIP CONTACT CUTTING Ø0.9 30-40A BACK STRIKING	
6	TIP CONTACT CUTTING Ø1.0 30-40A BACK STRIKING	80.-
7	FLAT TIP CUTTING Ø0.9 30-40A BACK STRIKING	
	FLAT TIP CUTTING Ø1.0 40-50A BACK STRIKING	
8	EXTENDED ELECTRODE BACK STRIKING	
9	EXTENDED TIP CONTACT CUTTING Ø0.65 10-20A BACK STRIKING	
	EXTENDED TIP CONTACT CUTTING Ø0.8 20-30A BACK STRIKING	
10	EXTENDED TIP CONTACT CUTTING Ø0.9 30-40A BACK STRIKING	
11	SHILED CUP (S-45)	480.-
	RETAINING CAP 6 HOLES MAXIMUM LIFE	
12	DOUBLE POINTED SPACERS (FOR USE WITH ITEM 5 AND 7 ONLY)	585.- net
N/S	WRENCH FOR ELECTRODE	
A	PT-40 70° HAND TORCH 4 m (12.5 ft) LEADS COAXIAL CABLE	
	PT-40 70° HAND TORCH 6 m (20 ft) LEADS COAXIAL CABLE	
	PT-40 70° LEAD ASSEMBLY 4 m (12.5 ft) LENGTH COAXIAL CABLE	
	PT-40 70° LEAD ASSEMBLY 6 m (20 ft) LENGTH COAXIAL CABLE	
B	PT-40 70° HAND TORCH 4 m (12.5 ft) LEADS COAXIAL CABLE	
	PT-40 70° HAND TORCH 6 m (20 ft) LEADS COAXIAL CABLE	
	PT-40 70° LEAD ASSEMBLY 4 m (12.5 ft) LENGTH COAXIAL CABLE	
	PT-40 70° LEAD ASSEMBLY 6 m (20 ft) LENGTH COAXIAL CABLE	
13	ELECTRODE	
14	TIP CONTACT CUTTING Ø0.9 30-40A	
15	ELECTRODE	
16	TIP CONTACT CUTTING Ø0.65 10-20A	
	TIP CONTACT CUTTING Ø0.8 20-30A	
	TIP CONTACT CUTTING Ø0.9 30-40A	
17	EXTENDED ELECTRODE	
18	EXTENDED TIP CONTACT CUTTING Ø0.9 30-40A	
19	DOUBLE POINTED SPACERS (FOR USE WITH ITEM 16 ONLY)	
N/S	CIRCLE CUTTING ATTACHMENT	